

## Toilet seat Subway / Omnia Architectura

**Model** — 98M9U0 Subway / Omnia Architectura toilet seat incl. hinge

**Product Description** — Subway / Omnia Architectura toilet seat in Wrap Over design made of color ingrained duroplast

- incl. hinge in stainless steel and nylon
- centre distance: 6 1/10" (155 mm)
- load of ring seat: 529,1 lbs (240 kg)
- 1 year guarantee

**Color Programme** — 01 White

**Hinge Finish** — 61 Stainless steel

**Spare parts** — A) 9223 70 61 Hinge in stainless steel and nylon  
B) 9223 68 00 Buffer for seat and cover

**Cleaning Instructions** — This toilet seat has been designed and manufactured with great care and attention to detail. If you follow a few simple cleaning instructions you will be able to enjoy its comfort, quality and beauty every day.

- In order to ensure the best possible hygiene the surface of the toilet seat is closed and pore-free. Please do not use abrasive, corrosive or chlorine based cleaners as these may lead to discoloration and flash rust. Please only use mild ph neutral soap for cleaning.
- If seat and cover make contact with toilet cleaners and or other aggressive cleaners, please immediately rinse with pure water.
- After cleaning please dry off any residual dampness with a soft cloth.
- Seat and cover must be left in an upright position until all cleaning agents in the bowl das been flushed away.

**Material Description** —

- TOILET SEAT: The material is colour ingrained duroplast (UF A 10 = urea formaldehyde) that contains no environmentally hazardous substances. UF plastic comprises 67% urea formaldehyde resin, 28% cellulose, as well as 5% minerals, pigments, lubricants and moisture content. The raw material from the supplier contains < 0.03% free formaldehyde and even less following curing.
- BUFFERS: PE (Polyethylene)
- HINGES: Stainless steel and nylon

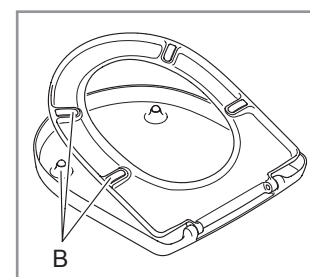
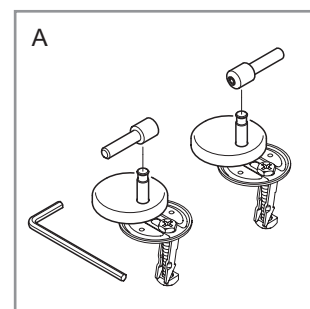
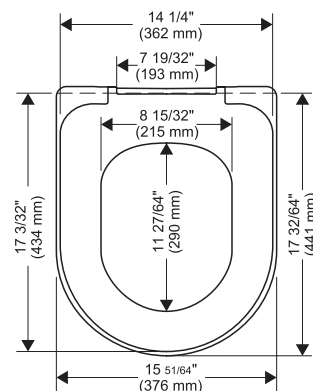

Villeroy & Boch AG  
PO box 11 20  
66688 Mettlach  
Germany

[www.villeroy-boch.com](http://www.villeroy-boch.com)

Service contact:  
E-mail: [inquiries@villeroy-boch-usa.com](mailto:inquiries@villeroy-boch-usa.com)  
Tel.: TOTO USA 888-295-8134



Villeroy & Boch

1748